

(No Model.)

H. C. & A. E. ZEUNERT.
CUT-OFF TOOL.

No. 550,671.

Patented Dec. 3, 1895.

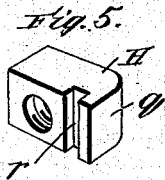
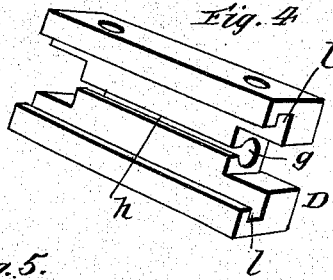
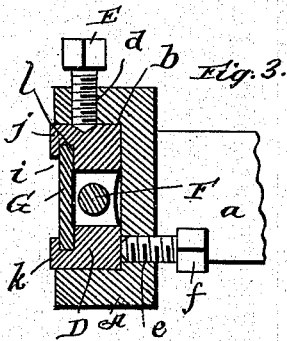
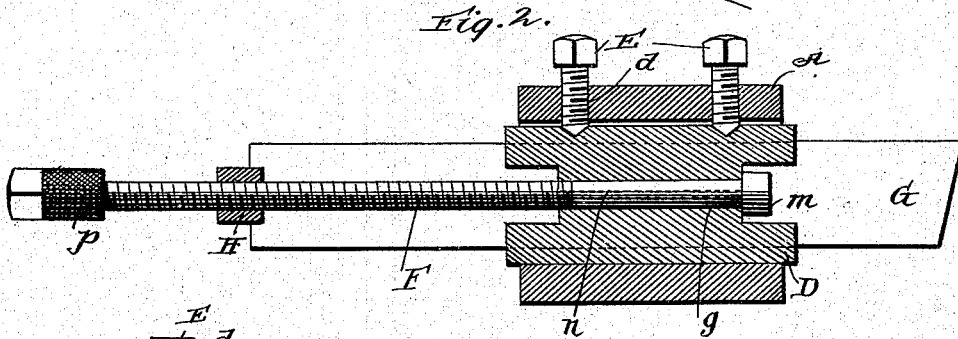
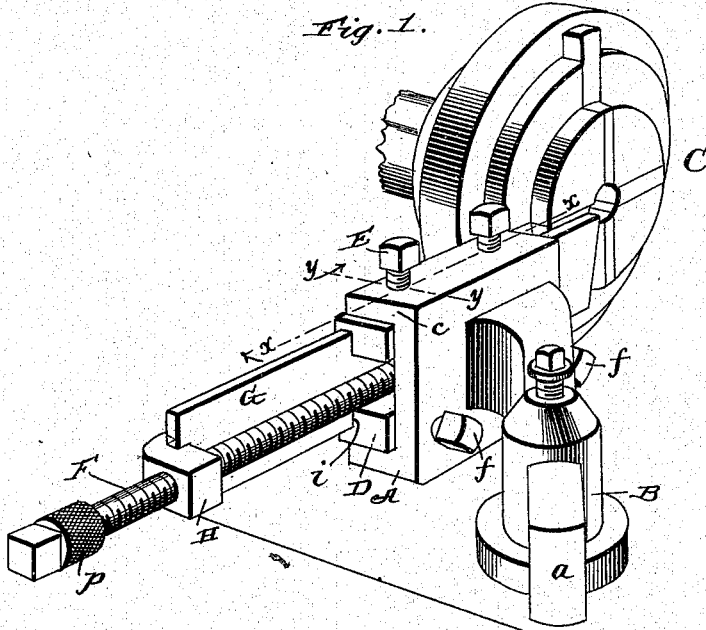

Witnesses:
C. Raeder
N. G. Matthews.

Inventors
H. C. Zeunert &
A. E. Zeunert.
 BY
James Sheehy
 Attorney

UNITED STATES PATENT OFFICE.

HANS C. ZEUNERT AND ARTHUR E. ZEUNERT, OF CHICAGO, ILLINOIS.

CUT-OFF TOOL.

SPECIFICATION forming part of Letters Patent No. 550,671, dated December 3, 1895.

Application filed March 20, 1895. Serial No. 542,539. (No model.)

To all whom it may concern:

Be it known that we, HANS C. ZEUNERT and ARTHUR E. ZEUNERT, citizens of the United States, residing at Chicago, in the county of Cook and State of Illinois, have invented certain new and useful Improvements in Cut-Off Tools; and we do declare the following to be a full, clear, and exact description of the invention, such as will enable others skilled in the art to which it appertains to make and use the same.

This invention relates to a cutting-off tool to be used on metal-working machines generally—such as lathes, shapers, planers, and the like; and, among other things, it has for its objects to provide, at a minimum expense, an effective means for moving or adjusting the blade laterally, so as to present a square cutting-surface; to so construct the sheath or blade holder that it may be clamped upon the blade by the manipulation of a screw or screws, so that said blade may be firmly secured in its seat and quickly adjusted, removed, and replaced in the holder without altering or changing the position of any of the parts, and which is highly advantageous in sharpening the blade; to so construct and combine the parts that the tool can be brought in close proximity to the chuck of a lathe or the like, which is an important desideratum, and, finally, to produce the tool as a whole at a comparatively small expense and so that there will be nothing about it which is weak or liable to get out of order.

Other objects and advantages will appear from the following description and claims, when taken in connection with the annexed drawings, in which—

Figure 1 is a perspective view of our improved tool, showing the same in connection with a tool-post and chuck with the blade in an operative position. Fig. 2 is a longitudinal sectional view taken in the plane indicated by the dotted line *xx* on Fig. 1. Fig. 3 is a cross-sectional view taken in the plane indicated by the dotted line *yy* on Fig. 1. Fig. 4 is a perspective view of the blade sheath or holder removed, and Fig. 5 is a perspective view of the sleeve-nut removed from the feed-screw.

In the said drawings similar letters designate corresponding parts in all of the views, referring to which—

A indicates the stock, having the integral arm *a* for attachment to a tool-post B, which may be that of a lathe or other metal-working machine, and C indicates a chuck, which, however, forms no part of my invention, but is here shown for the purpose of better illustrating my improvements.

The stock A is provided in its side, opposite the arm *a*, with a longitudinal slot or opening *b* for the reception of the sheath or blade-holder D. The top wall *c* of this slot or opening is provided with two screw-tapped apertures *d* to receive headed bolts or screws E, which are designed to engage the sheath or blade-holder, as will be presently described. In the vertical side wall of the stock we also provide two screw-tapped apertures *e* for the reception of screws *f*, which engage one side of the blade-holder D, and preferably near the base thereof.

The sheath or blade-holder D may be of a general elongated rectangular form in outline and is bored out centrally and longitudinally, as shown at *g*, for the reception of the feed-screw F, and this bored-out portion is split in its outer wall throughout its length, as shown at *h*, for a purpose presently described. Said sheath or blade-holder D is also recessed longitudinally, as shown at *i*, and in the top and bottom walls *j k* of this recess are formed grooves *l*, designed and adapted to receive the blade G, as shown in Figs. 1 and 3 of the drawings.

As better shown in Fig. 2, the feed-screw F is provided at one end with a head *m*, designed to engage the forward end of the sheath or blade-holder D and with a plain or smooth portion *n*, designed to rest in the bore *g* of said sheath or blade-holder, and at its opposite end said screw is provided with a head *p*, partly milled and partly squared, as illustrated, whereby it may be readily turned by hand or with a wrench or other suitable implement. The threads of the screw F preferably extend from the head *p* to the plain portion *n*, and they are designed for the engagement of the sleeve-nut H, better illus-

trated in Fig. 5. This sleeve-nut is provided with a wing *g*, in which is formed a groove or seat *r* to receive the rear end of the blade, as shown in Fig. 1, and when said nut is in engagement with the blade and the screw is turned the nut will be held against turning by the blade and with said blade will be moved forward. Said nut also serves in practice to hold the blade *G* to its place and prevent rearward movement of the same.

In the practice of our invention the parts are assembled as shown in Fig 1—that is to say, the sheath or holder *D* is placed in the stock *A*, the blade is placed in said sheath or holder, and the sleeve-nut is placed in engagement with the blade, after which the blade is adjusted forwardly to the proper position by turning the feed-screw in the proper direction. When this has been done, the screws *E* are turned downwardly to secure the sheath or holder *D* in the stock and also to clamp said sheath or holder, which, on account of its peculiar construction, is more or less resilient upon the blade, so as to securely hold said blade in position. In case it is found that the cutting-blade is not presented at the proper angle to the axis of the lathe and the article to be cut, it is simply necessary, in order to get a square cutting-surface, to turn the screws *f*, so as to slightly move the sheath or holder *D* and consequently the blade laterally. After the blade has been adjusted to and secured in its proper position and the piece of metal to be cut is fixed in the chuck the blade *G* may be readily adjusted toward or from the chuck so as to cut at the desired distance therefrom by simply loosening the binding-screw of the tool-post and moving the arm or shank *a* of the stock therein until the blade is in the desired position, when the screw may be tightened and the stock and shank adjustably secured in position. When it is necessary to grind or sharpen the blade *G*, it may be taken out of the holder by loosening the top screws *E*, which engage the depressions *t* in the sheath or holder and reversing the feed-screw *F*, and may be sharpened and then conveniently replaced in the exact position it occupied with respect to the chuck and the piece of metal held thereby. This may be accomplished, as will be observed, because it is not necessary to move the stock *A* or the sheath or holder *D* in order to remove the blade, and it is an important advantage, as is obvious.

It will be observed from the foregoing that with its many advantages my improved cutting-off tool is very simple and durable, and that it may be manufactured almost, if not quite, as cheaply as the tools at present in use.

We have in some respects specifically described the construction and relative arrangement of the parts of our improved tool in order to impart a full, clear, and exact understanding of the same; but we do not desire

to be understood as confining ourselves to such construction and arrangement, as we reserve the right to make in practice such changes or modifications as fairly fall within the scope of our invention.

Having described our invention, what we claim, and desire to secure by Letters Patent, is—

1. In a cutting off tool, the combination of a stock having a recess in one of its sides, a sheath or guide arranged in said recess, a blade carried by the sheath or guide, and a screw extending transversely through the inner wall of the recess in the stock and bearing at its inner end against the inner side of the sheath or guide and adapted to adjust said sheath or guide and the blade therein laterally or in the direction of the open side of the recess in the stock, substantially as specified.

2. In a cutting off tool, the combination of a stock having a recess in one of its sides, a sheath or guide arranged in the recess of the stock, a blade arranged in the sheath or guide means for feeding the blade into the work, a screw taking through one of the walls of the recess in the stock and bearing against the sheath or guide and adapted to secure it in the stock and clamp it upon the blade, and a screw extending transversely through the inner wall of the recess in the stock and bearing at its inner end against the sheath or guide and adapted to adjust said sheath or guide and the blade therein laterally or in the direction of the open side of the recess in the stock, substantially as specified.

3. In a cutting off tool, the combination of a sheath or guide formed in one piece and having a longitudinal bore, the wall of which is slotted throughout its length and also having a recess in one of its sides communicating with the slot in its bore, a blade arranged in said recess of the sheath or holder, and a suitable means for clamping the sheath or holder on the blade, substantially as and for the purpose specified.

4. In a cutting off tool, the combination of a stock, a sheath or holder arranged in the stock and having a longitudinal smooth bore, a blade carried by the sheath or holder in the stock and clamping it on the blade, a feed screw having a plain portion journaled in and extending through the smooth bore of the sheath or guide and also having an enlargement for engaging the sheath or guide and a nut arranged on the threaded portion of said screw and engaging the end of the blade, substantially as and for the purpose set forth.

5. In a cutting off tool, the combination of a stock having a recess in one of its sides and also having a shank or arm extending from its opposite side and adapted to be arranged and adjustably secured in a tool post,

a sheath or guide arranged in the recess of
the stock and having a longitudinal bore and
also having a recess in one of its sides, a
blade arranged in the recess of the sheath or
5 guide, a screw taking through the stock and
engaging the sheath or guide and adapted to
clamp it on the blade, a screw taking through
the stock and engaging the sheath or guide
and adapted to adjust it and the blade therein
10 laterally, a feed screw arranged in the bore of

the sheath or guide and a nut mounted on said
screw and engaging the blade, all substan-
tially as and for the purpose set forth.

In testimony whereof we affix our signa-
tures in presence of two witnesses.

HANS C. ZEUNERT.

ARTHUR E. ZEUNERT.

Witnesses:

GUS YOUNGQUIST,

EMIL VOSS.